

BETTACRETE PRECAST PTY LTD

ABN 11 007 643 790

152 Port Wakefield Rd Cavan SA 5094

Telephone: (08) 8262 1042

Facsimile: (08) 8260 2460

Website: www.bettacrete.com.auEmail: sales@bettacrete.com.au

CONCRETE IN-GROUND WATER TANKS

9,000 Litre

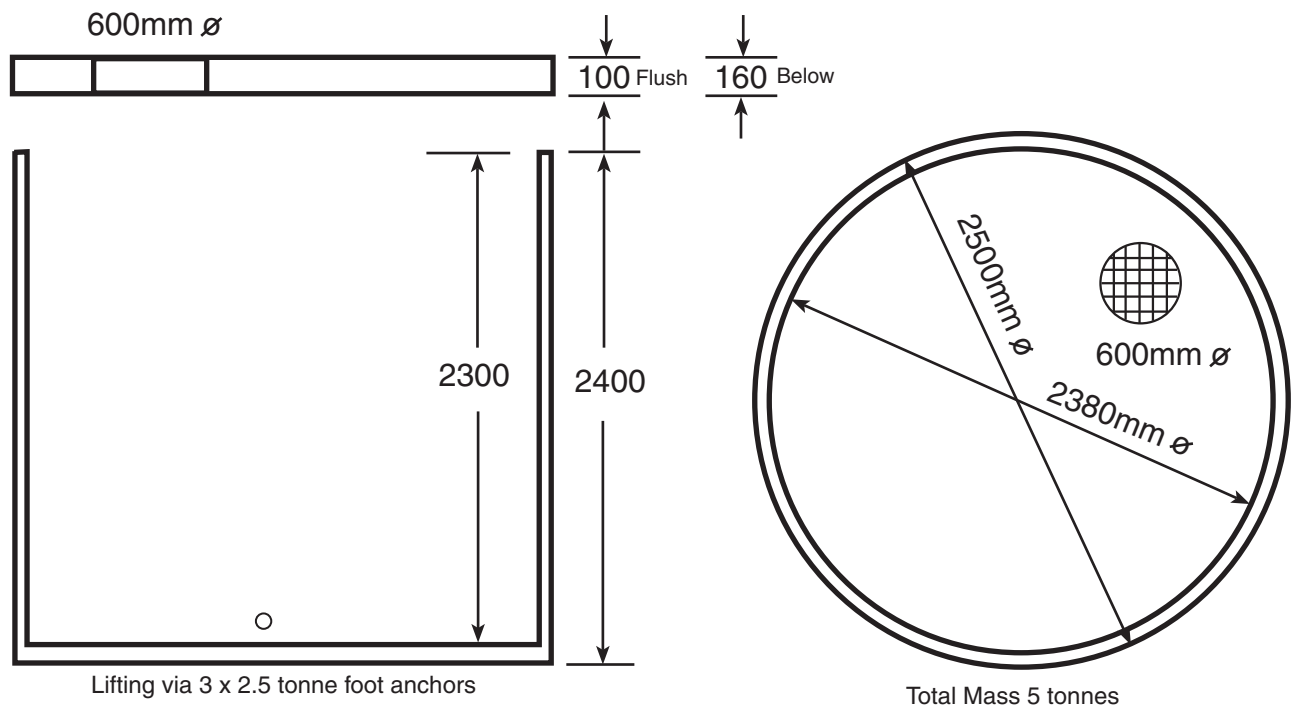

Bettacrete Concrete tanks are designed to go underground, thus not wasting precious space. Tanks can be supplied to finish flush with the surface (Round Concrete Coverslab) or up to 900mm below the surface.

Tank is fitted with a 600mm Dia. Cast Iron access cover, inlet and outlet penetrations can be customised to suit your own application.

Site Preparation – Excavate to the required depth plus 75mm, place a 75mm level bed of 10mm screenings on the base, it is recommended that the tank be partially filled with water immediately after positioning to avoid tank "floating". When back filling avoid large "rocks" and compact well.

9,000 Litre tanks may be placed immediately behind the delivery truck or immediately alongside, provided clear access is available. Site must be level and clear of overhead power lines, trees etc.