

**BETTACRETE PRECAST PTY LTD**

ABN 11 007 643 790

152 Port Wakefield Rd Cavan SA 5094

Telephone: (08) 8262 1042

Facsimile: (08) 8260 2460

Website: [www.bettacrete.com.au](http://www.bettacrete.com.au)

Email: [sales@bettacrete.com.au](mailto:sales@bettacrete.com.au)



# CONCRETE IN-GROUND WATER TANKS

## 5,000 Litre

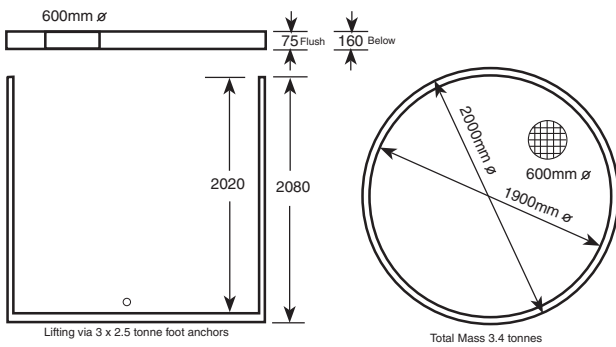

Bettacrete tanks are designed to go underground, thus not wasting precious space. Tanks can be supplied with a light-duty Coverslab designed to finish flush with the ground or with a heavy duty Coverslab designed to go up to 900mm below ground.

## 9,000 Litre

Coverslabs come complete with a 600mm Dia. Cast Iron Access Cover. (Concrete Access Cover only in 5000 Litre.)

Inlet and Outlet penetrations can be custom made to suit individual applications.

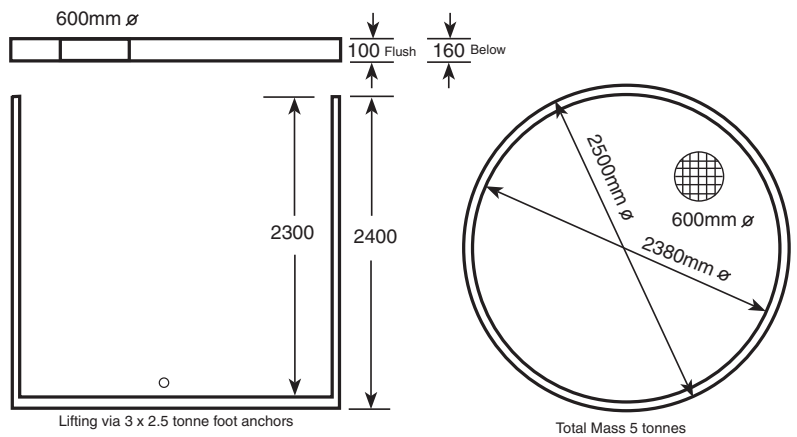

## 22,000 Litre

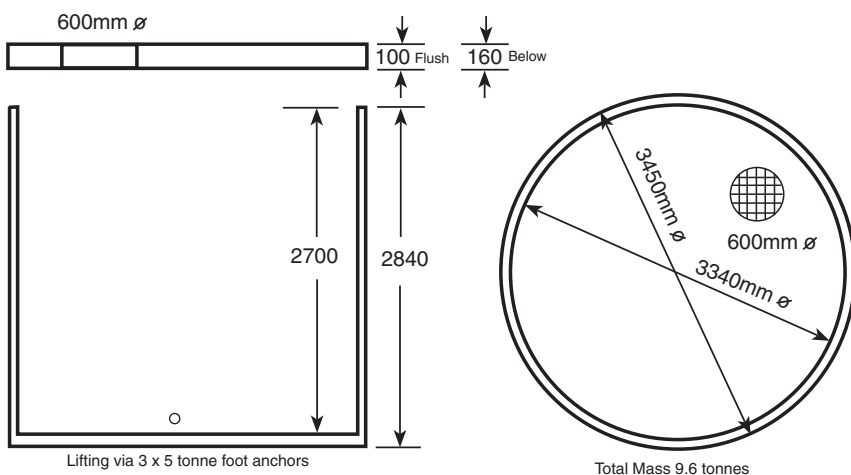

Access Risers also available up to 900mm for below ground applications.

Manufactured with Fibre Reinforced, Vibrated High Strength Concrete.